

About Working Pressure

The tables on the following pages list the recommended working pressure for a variety of hydraulic fittings made in accordance with world standards. Many factors such as impulse, vibration, mechanical shock, and improper assembly may affect the integrity of the fitting connection.

Tompkins Industries and SAE International™ recommend sufficient testing be conducted to ensure that performance levels will be safe and satisfactory, especially if installed in systems operating at elevated pressures or in severe conditions. Working pressure ratings are capable of a 4 to 1 minimum burst. All steel fittings meet or exceed the minimum SAE pressure ratings. Always consider application and maximum pressure requirements when selecting fittings.

WARNING: WHEN USING A FITTING WITH VARYING CONNECTION SIZES OR TYPES, DO NOT EXCEED THE WORKING PRESSURE OF THE LOWEST RATED CONNECTION END COMPRISING THE FITTING.

For pressures exceeding SAE standards, please contact the Tompkins Technical Staff.

Methods for Installing Fittings

There are three methods for installing a fitting:

- Torque wrench
- Flats From Wrench Resistance (FFWR)
- Turns From Finger Tight (TFFT)

For Flare and NPSM Fittings, Tompkins recommends the FFWR method be used whenever possible. When torque wrenches are not available or usable, use the FFWR method.

The differences in materials, plating, and surface finish impacts the coefficient of friction when installing or connecting fittings. To minimize these variances, Tompkins recommends that fitting connections are lubricated when installed. Connections that are lubricated provide a more accurate installation torque, which results in significantly fewer leaks.

Using a Torque Wrench

The torque values given in the tables on the following pages are for reference purposes only based on industry standard practice and for low carbon steel mating with steel/iron components. Actual torque values may need to be adjusted due to variances described above.

SAE recommends always making a wet (lubricated) installation or connection to reduce friction on moving parts, O-rings, and variances in material and plating. The torque values in these tables are based off SAE values using a .17 coefficient of friction as per SAE J2593. For torque on softer materials such as brass or aluminum, reduce the value in the table by 1/3. Example, 30 ft/lbs would be 20 ft/lbs. Many hydraulic leaks are a result of over-torque, which causes excessive deformation of material or exceeds the yield strength of the material, which may reduce the load or clamping force between seal contacts.

If more than one value or range is given, use the lower value first and increase only if required. Over-torquing can damage a fitting or mating component.

Using Turns From Finger Tight (TFFT) For Tapered Fittings

Turns From Finger Tight (TFFT) is the preferred method for tapered fittings such as NPT and BSPT. Taper threaded ports and fittings seal on the threads engaging each other, but do require a sealant to insure sealing.

NPT threaded connections can have a small void at the root/crest junction when external and internal thread flanks make contact. Without the application of a proper thread sealant to fill this void, a spiral leak path will occur.

On NPTF threads (*Figure 2*), the root and crest are machined with higher precision and a smaller tolerance enabling the flanks to contact more area, further minimizing the crest to root void. Even though NPTF threaded connections are more precise, they also require a thread sealant prior to installation to improve sealing.

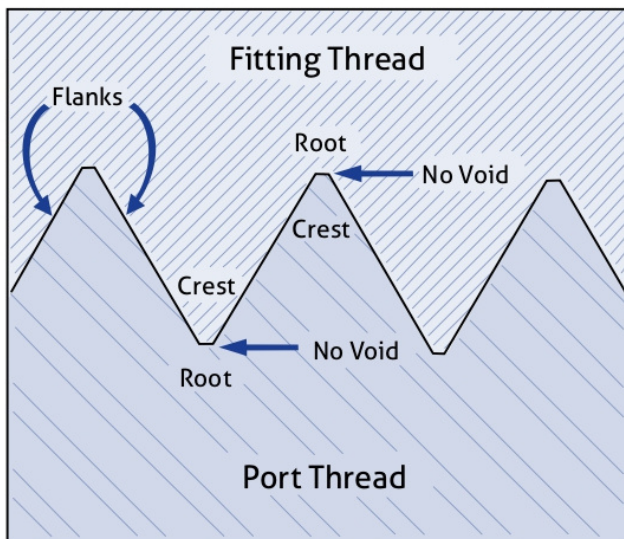

Figure 2 : NPTF Thread View

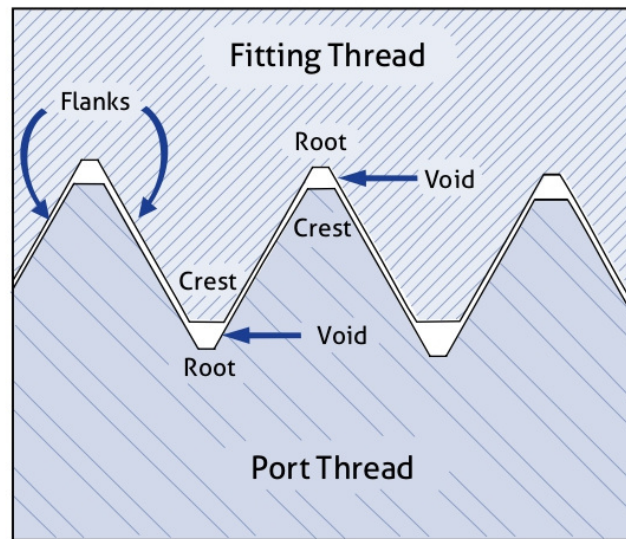

Figure 3 : NPT Thread View

BSPT and Metric tapered threads work and are installed in the same manner as NPT and NPTF. Confirm with the thread sealant supplier instructions that you are using the correct sealant for the application.

Because of the extent of variables involved in this type of seal such as material, type of sealant, thread quality and other factors, the TFFT method helps insure the correct torque is applied. This method focuses on the number of threads engaged rather than a set applied installation force (i.e. ft-lbs). From the point of finger tight is when the turns are counted. Then using a wrench, further tighten the fitting the correct number of turns or full revolutions from finger tight.

Visit the website at tompkinsind.com for more information about using our products, helpful assembly video information, product identification, CAD drawings and our wide range of product lines.

Using Flats From Wrench Resistance (FFWR) For Flared Fittings

Flats From Wrench Resistance (FFWR) is the preferred method of connecting flared fittings such as JIC and NPSM. Due to variance in materials, flared fittings are more susceptible to over-torque because of the cone collapse during connection. Tompkins Industries, SAE International, and other fitting suppliers recommend that the FFWR method be used for flared fitting connections whenever possible. When torque wrenches are not available, the FFWR may be used for other fitting installation connection types.

The Flats From Wrench Resistance (FFWR) method is based on the hexagon or hex nut of a fitting. The hex nut is divided into angles of rotation of a circle or 360°. One hex nut side is a Flat and makes up of 1/6 of the circle or 60°. Hence, to turn one flat is equal to 60° of rotation.

For example, we can think of a hex nut like a clock face. One flat equals 2 hours or 60° (Figure 1).

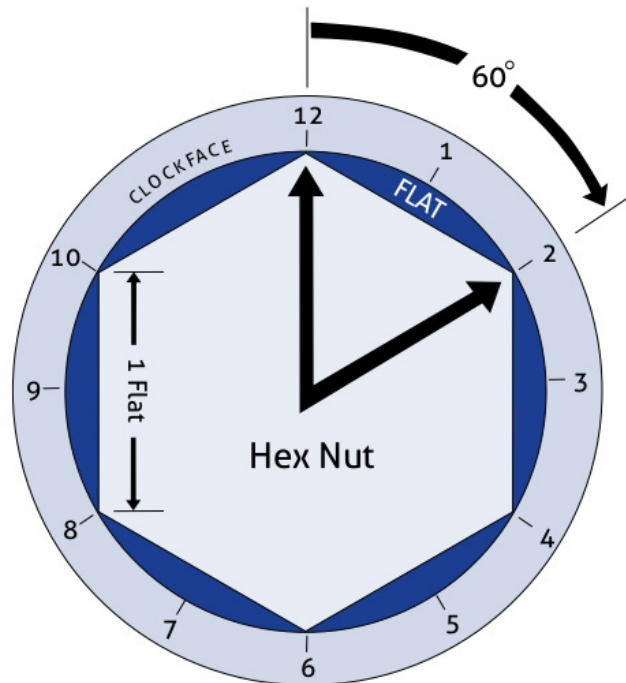

Figure 1: FFWR Diagram

SAE O-Ring Boss Port Specifications

O-ring Boss ports (ORB) provide a seal by trapping the fitting's O-ring inside a port cavity. When a fitting is installed into the port, the O-ring is trapped between the fitting body hex or washer and port cavity.

Straight fittings include a hex, and sometimes an additional cylindrical shoulder below the hex and above the threads, to trap the O-ring in the port cavity.

Elbow and Tee fittings require a backup washer and a locknut above the O-ring on the threaded stud to permit a 360° orientation of the fitting around the port.

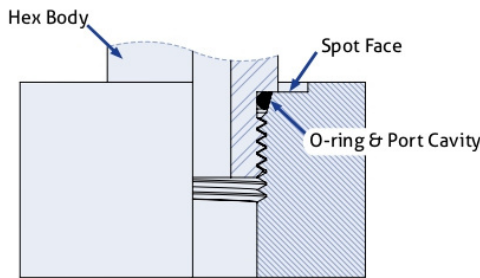

Figure 5 : Straight SAE ORB

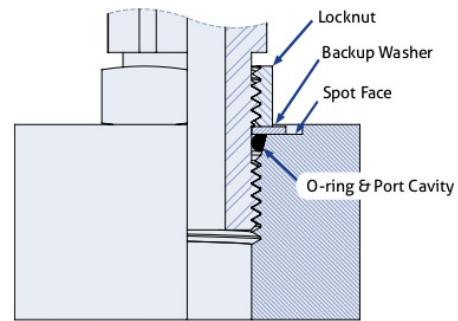

Figure 6: Adjustable SAE ORB

The following table lists the specifications for SAE O-Ring Boss Ports.

SAE O-Ring Boss Specifications								
Dash Size	Tube Size	Thread	SAE-ORB to JIC and Pipe Fittings*			SAE-ORB to ORFS Fittings**		
			Torque	Working Pressure		Torque	Working Pressure	
			Adjustable & Non-Adjustable	Adjustable	Non-Adjustable	Adjustable & Non-Adjustable	Adjustable	Non-Adjustable
			(ft-lbs) +25% -0%	(psi)	(psi)	(ft-lbs) +25% -0%	(psi)	(psi)
02	1/8	5/16-24	6	4500	4500	-	-	-
03	3/16	3/8-24	7	4500	4500	7	5800	9100
04	1/4	7/16-20	13	4500	4500	15	5800	9100
05	5/16	1/2-20	18	4500	4500	18	5800	9100
06	3/8	9/16-18	22	3600	4500	26	5800	9100
08	1/2	3/4-16	37	3600	4500	52	5800	9100
10	5/8	7/8-14	44	2900	3600	74	5800	9100
12	3/4	1-1/16-12	70	2900	3600	125	5800	5800
14	7/8	1-3/16-12	92	2300	2900	158	5800	5800
16	1	1-5/16-12	111	2300	2900	199	4500	5800
20	1 1/4	1-5/8-12	147	1800	2300	210	3600	3600
24	1 1/2	1-7/8-12	155	1800	2300	273	2900	3600
32	2	2-1/2-12	221	1450	1800	-	-	-

* = Light duty studs included on JIC, NPTF and NPSM fittings per SAE J1926/3 & J1514
 ** = Heavy duty studs included on ORFS fittings per SAE J1926/2 & J1453
 Note: Torque values are for wet torque and are allowed up to 25% the listed value according to SAE J2593.

Table 2: SAE O-Ring Boss Specifications

JIC Adapter Specifications

Male flared fittings include a conical nose with external threads for clamping.

A flared fitting or tube assembly is tightened against the cone with a swivel nut. By forcing the flare against the cone during the torquing process, the nose cone is slightly deformed and meshes to create a metal to metal seal between the flare and the cone.

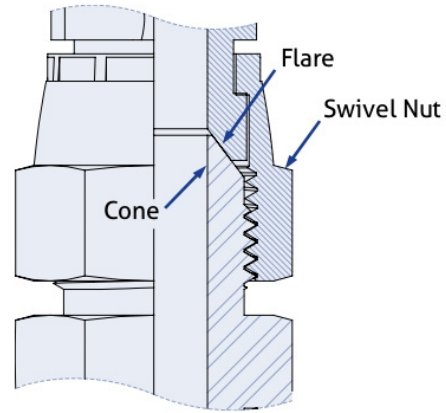

Figure 4: Flare Fitting Assembly

The following table lists the specifications for JIC adapters.

JIC Specifications							
Dash Size	Tube Size	Thread	Working Pressure		Torque		
			Male	Female Swivel Nut	JIC Rigid	JIC Swivel	Bulkhead Locknut
			(psi)	(psi)	(FFWR)	(FFWR)	(ft-lbs) +25% - 0%
02	1/8	5/16-24	5000	5000	1/4 - 1/2	2	4
03	3/16	3/8-24	5000	5000	1/4 - 1/2	2	6
04	1/4	7/16-20	5000	4500	1/4 - 1/2	2	10
05	5/16	1/2-20	5000	4000	1/4 - 1/2	2	13
06	3/8	9/16-18	5000	4000	1/4 - 1/2	2	16
08	1/2	3/4-16	4500	4000	1/4 - 1/2	2	27
10	5/8	7/8-14	3500	3000	1/4 - 1/2	1 1/2	32
12	3/4	1-1/16-12	3500	3000	1/4 - 1/2	1 1/2	52
14	7/8	1-3/16-12	3000	2500	1/4 - 1/2	1 1/2	66
16	1	1-5/16-12	3000	2500	1/4 - 1/2	1 1/2	85
20	1 1/4	1-5/8-12	2500	2000	1/4 - 1/2	1	111
24	1 1/2	1-7/8-12	2000	1500	1/4 - 1/2	1	114
32	2	2-1/2-12	1500	1125	1/4 - 1/2	1	162

Values are per SAE J514

Tompkins does not recommend torque wrench installation of flared fittings. If you wish to use torque installation, contact Tompkins Technical Staff.

Table 1 : JIC Specifications

Pipe & Pipe Swivel Adapter Specifications

NPSM fittings include an inverted 60° cone inside an internally threaded swivel union nut. Male NPTF fittings that have a 30° internal chamfer that make a 60° inverted cone, will mate with NPSM swivel unions (*Figure 7*).

NOTE: THE MATING MALE THREADS MUST INCLUDE AN INSIDE CHAMFER ON THE END OF THE FITTING THAT MATES WITH THE INVERTED CONE. THREADS ARE FOR CLAMPING FORCE ONLY AND THE SEALING OCCURS ON A SMALL RADIAL SECTION BETWEEN THE MALE FITTING INTERNAL CHAMFER AND THE SWIVEL UNION INVERTED CONE.

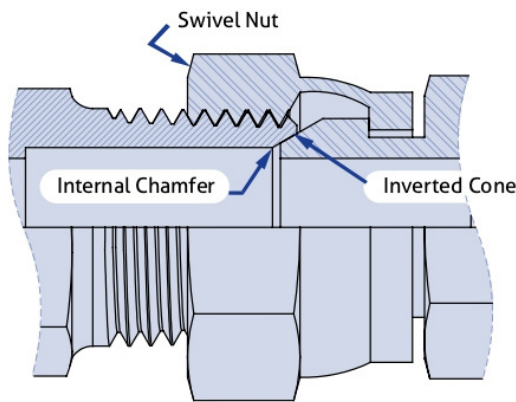

Figure 7 : NPTF & NPSM Union

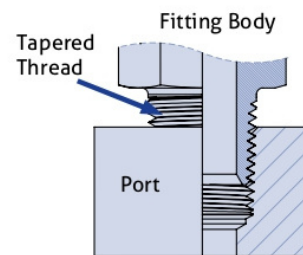

Figure 8: NPT & NPTF Assembly

NPT and NPTF (*Figure 8*) pipe threads seal by wedging the tapered threads through deformation into each other. Both of these threads require thread sealants to complete a seal.

The following table lists the specifications for NPT, NPTF, and NPSM Pipe adapters.

NPT, NPTF, and NPSM Pipe Specifications						
Dash Size	Thread Size	Major OD* (inch)	Working Pressure		Torque	
			NPT, NPTF Male and Female	NPSM Female Swivel Nut	NPT, NPTF	NPSM Swivel Union
			(psi)	(psi)	(TFFT)	(FFWR)
02	1/8-27	.405	5000	5000	2-3	2
04	1/4-18	.540	4000	5000	2-3	2
06	3/8-18	.675	3000	4000	2-3	2
08	1/2-14	.84	3000	3500	2-3	2
12	3/4-14	1.050	2500	2250	2-3	2
16	1-11 1/2	1.315	2000	2000	1 1/2 - 2 1/2	1 1/2
20	1 1/4-11 1/2	1.660	1150	1625	1 1/2 - 2 1/2	1 1/2
24	1 1/2-11 1/2	1.900	1000	1250	1 1/2 - 2 1/2	1 1/2
32	2-11 1/2	2.375	1000	1125	1 1/2 - 2 1/2	1 1/2

Values are per SAE J514 & J2593

Table 3: NPT, NPTF, and NPSM Pipe Specifications

O-ring Face Seal Adapter Specifications

O-ring face seal fittings include a precision groove in the face of the male fitting. Sealing occurs when an O-ring is trapped in the groove by a smooth flat flange that is clamped against the face with a nut or nut and sleeve. The flat flange may be formed or brazed onto the end of a tube, or is machined on a fitting. (Figure 9)

There are two SAE groove types:

- Type A: The original style A O-ring has no retaining ledge. (Figure 10)
- Type B: The Type B groove has a retaining ledge (half dovetail) that improves O-ring retention. The Type B style is more commonly found and is a design improvement over the Type A. (Figure 11)

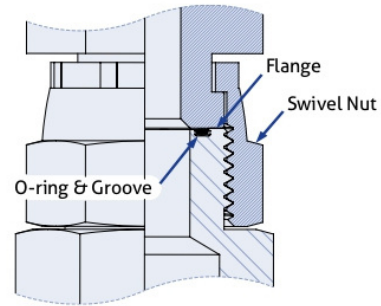

Figure 9: ORFS Fitting Assembly

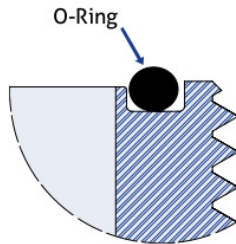

Figure 10: Detail View of Cross Section of Groove Type A

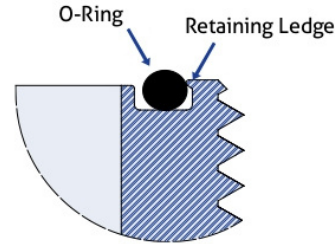

Figure 11: View of Groove Type B

The following table lists the specifications for O-ring Face Seal adapters.

ORFS Specifications								
Dash Size	Tube Size	Thread Size	Working Pressure		Torque			
			Male	Female Swivel Nut	Male & Female	Bulkhead Locknut	Tube Nuts	Swivel Nuts
			(psi)	(psi)	(ft-lbs) +25% -0%	(ft-lbs) +25% -0%	FFWR	FFWR
04	1/4	9/16-18	6000	6000	18	16	1/4-1/2	1/2-3/4
06	3/8	11/16-16	6000	6000	29	22	1/4-1/2	1/2-3/4
08	1/2	13/16-16	6000	6000	41	29	1/4-1/2	1/2-3/4
10	5/8	1-14	6000	6000	44	44	1/4-1/2	1/2-3/4
12	3/4	1-3/16-12	6000	6000	66	66	1/4-1/2	1/3-1/2
16	1	1-7/16-12	6000	5000	92	92	1/4-1/2	1/3-1/2
20	1 1/4	1-11/16-12	4000	4000	125	111	1/4-1/2	1/3-1/2
24	1 1/2	2-12	4000	3000	147	125	1/4-1/2	1/3-1/2

Note: Values are per SAE J2593 & J1453

Torque values are for wet installation of steel components. Reduce torque values for softer material components.

Table 4: ORFS Specifications

Code 61 & 62 Flange Specifications

Flange ports have a smooth machined surface with four threaded holes around the port. The threads provide a clamping force for the flange against the port. An O-ring seal is trapped in the flange fitting around the port. (Figure 12)

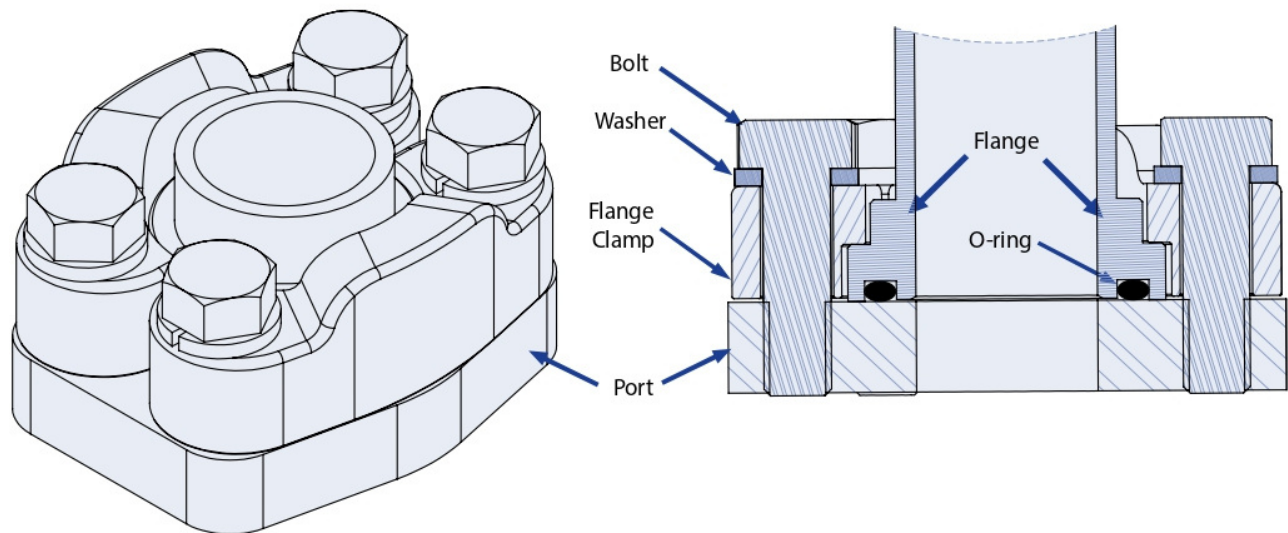

Figure 12 : Flange Port Assembly (Left) Cross Section Flange Port Assembly (Right)

The flange may be a single piece or an assembly (single piece flange is not shown). A single flange piece has four holes that mate with the clamping holes. The assembly flange is a cylindrical shape and is clamped with a full circle flange clamp containing four bolt holes, or with two split flange clamps containing two bolt holes each. (Figure 12)

There are two pressure-rated standards:

- Code 61 (Standard Pressure)
- Code 62 (High Pressure)

Each style and size has a unique bolt pattern. The high pressure Code 62 assembly flanges have a larger diameter and thickness than the standard pressure Code 61 flanges.

Code 61 (Standard Pressure) Flanges

The following table lists the specifications for Code 61 flanges.

Flange Code 61 Specifications				
Dash Size	Tube Size	Working Pressure	Torque*	Torque**
		(psi)	+10%- 0% (ft-lbs)	+10%- 0% (ft-lbs)
08	1/2	5000	18	24
12	3/4	5000	32	44
16	1	5000	32	44
20	1 1/4	4000	52	68
24	1 1/2	3000	77	111
32	2	3000	77	111
40	2 1/2	2500	77	111
48	3	2000	155	217
56	3 1/2	500	155	217
64	4	500	155	217

Torque values are per SAE J2593 and for wet installation of steel components. Reduce torque values for softer material components.

* Torque for SAE Grade 5 Screws
** Torque for SAE Grade 8 Screws

Table 5: Flange Code 61 Specifications

The following table lists the dimensions for Code 61 flanges.

Flange Code 61 Dimensions								
Dash Size	Tube Size	C	E	Q	GG	A	Z INCH Threads	Z METRIC Threads
08	1/2	1.188	0.265	1.5	0.688	0.50	5/16-18	M8 x 1.25
12	3/4	1.500	0.265	1.875	0.875	0.75	3/8-16	M10 x 1.5
16	1	1.750	0.315	2.082	1.031	1.00	3/8-16	M10 x 1.5
20	1 1/4	2.000	0.315	2.312	1.188	1.25	7/16-14	M10 x 1.5
24	1 1/2	2.375	0.315	2.750	1.406	1.50	1/2-13	M12 x 1.75
32	2	2.812	0.375	3.062	1.688	2.00	1/2-13	M12 x 1.75
40	2 1/2	3.312	0.375	3.500	2.000	2.50	1/2-13	M12 x 1.75
48	3	4.000	0.375	4.188	2.438	3.00	5/8-11	M16 x 2
56	3 1/2	4.500	0.422	4.750	2.750	3.50	5/8-11	M16 x 2
64	4	5.000	0.442	5.125	3.062	4.00	5/8-11	M16 x 2

Hex head bolts are grade 5 and socket head cap bolts are grade 8.

Table 6: Flange Code 61 Dimensions

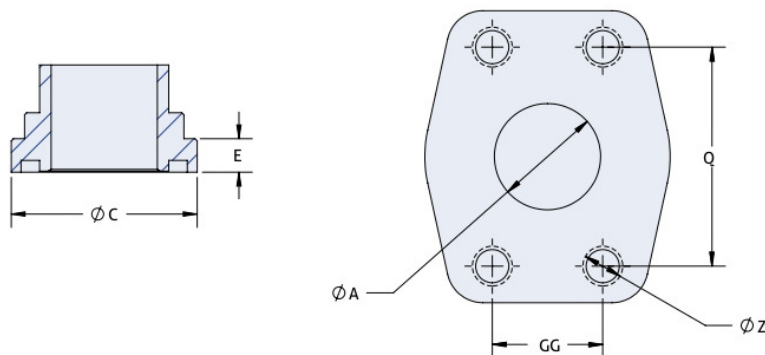

Figure 13 : Code 61 and 62 Figures of the flange (Left) and bolt pattern (Right)

Code 62 (High Pressure) Flanges

The following table lists the specifications for Code 62 flanges.

Flange Code 62 Specifications					
Dash Size	Tube Size	Working Pressure	Torque Range*	Average Torque*	Torque**
		(psi)	(in-lbs)	(ft-lbs)	+10%- 0% (ft-lbs)
08	1/2	6000	175-225	17	24
12	3/4	6000	300-400	29	44
16	1	6000	500-600	46	68
20	1 1/4	6000	750-900	69	111
24	1 1/2	6000	1400-1600	125	217
32	2	6000	2400-2600	208	332

Standards per SAE J2593 & J518

*Torque for SAE Grade 5 Screws
 **Torque for SAE Grade 8 Screws

Table 7: Flange Code 62 Specifications

The following table lists the dimensions for Code 62 flanges.

Flange Code 62 Dimensions								
Dash Size	Tube Size	C	E	Q	GG	A	Z INCH Threads	Z METRIC Threads
08	1/2	1.250	0.305	1.594	0.718	0.50	5/16-18	M8 x 1.25
12	3/4	1.625	0.345	2.00	0.937	0.75	3/8-16	M10 x 1.5
16	1	1.875	0.375	2.250	1.093	1.00	7/16-14	M12 x 1.75
20	1 1/4	2.125	0.405	2.625	1.250	1.25	1/2-13	M14 x 2.0
24	1 1/2	2.500	0.495	3.125	1.437	1.50	5/8-11	M16 x 2.0
32	2	3.125	0.495	3.812	1.750	2.00	3/4-10	M20 x 2.5

Note: Hex head bolts are grade 5 and socket head cap bolts are grade 8.

Table 8: Flange Code 62 Dimensions

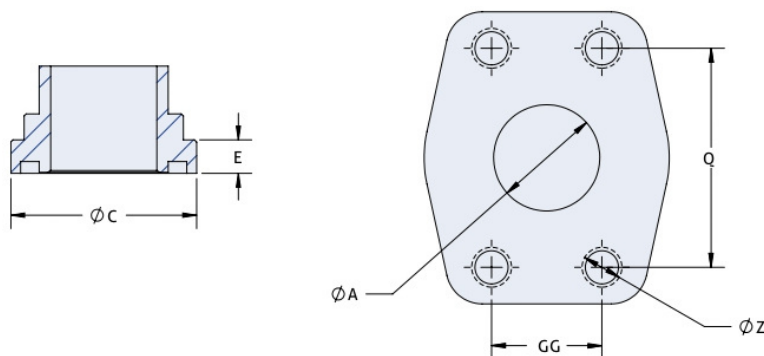

Figure 13 : Code 61 and 62 Figures of the flange (Left) and bolt pattern (Right)

Code 62 (High Pressure) Flanges

The following table lists the specifications for Code 62 flanges.

Flange Code 62 Specifications					
Dash Size	Tube Size	Working Pressure	Torque Range*	Average Torque*	Torque**
		(psi)	(in-lbs)	(ft-lbs)	+10%- 0% (ft-lbs)
08	1/2	6000	175-225	17	24
12	3/4	6000	300-400	29	44
16	1	6000	500-600	46	68
20	1 1/4	6000	750-900	69	111
24	1 1/2	6000	1400-1600	125	217
32	2	6000	2400-2600	208	332

Standards per SAE J2593 & J518

*Torque for SAE Grade 5 Screws
 **Torque for SAE Grade 8 Screws

Table 7: Flange Code 62 Specifications

The following table lists the dimensions for Code 62 flanges.

Flange Code 62 Dimensions								
Dash Size	Tube Size	C	E	Q	GG	A	Z INCH Threads	Z METRIC Threads
08	1/2	1.250	0.305	1.594	0.718	0.50	5/16-18	M8 x 1.25
12	3/4	1.625	0.345	2.00	0.937	0.75	3/8-16	M10 x 1.5
16	1	1.875	0.375	2.250	1.093	1.00	7/16-14	M12 x 1.75
20	1 1/4	2.125	0.405	2.625	1.250	1.25	1/2-13	M14 x 2.0
24	1 1/2	2.500	0.495	3.125	1.437	1.50	5/8-11	M16 x 2.0
32	2	3.125	0.495	3.812	1.750	2.00	3/4-10	M20 x 2.5

Note: Hex head bolts are grade 5 and socket head cap bolts are grade 8.

Table 8: Flange Code 62 Dimensions

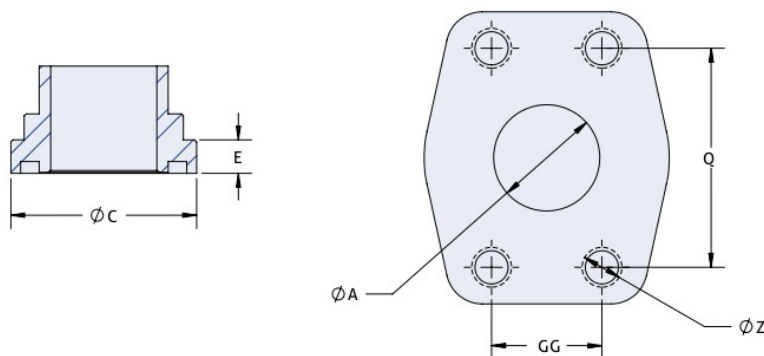

Figure 13 : Code 61 and 62 Figures of the flange (Left) and bolt pattern (Right)

BSPT, BSPP (DIN 3852-2) and Metric (DIN 3852-1) Adapter Specifications

BSPT and Metric tapered threads install and work in the same manner as NPT and NPTF.

Male BSPP fittings include an inverted 60° cone inside an internally threaded swivel union nut. (Figure 15) Male BSPP fittings that have a 30° internal chamfer that make a 60° inverted cone, will mate with Female BSPP swivel unions.

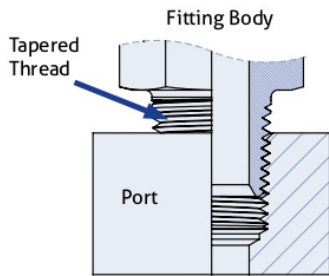

Figure 14: BSPT Assembly

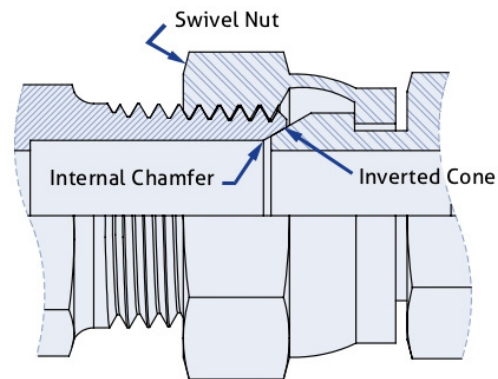

Figure 15: BSPP Union

NOTE: THE MATING MALE THREADS MUST INCLUDE AN INSIDE CHAMFER ON THE END OF THE FITTING THAT MATES WITH THE INVERTED CONE. THREADS ARE FOR CLAMPING FORCE ONLY AND THE SEALING OCCURS ON A SMALL RADIAL SECTION BETWEEN THE MALE FITTING INTERNAL CHAMFER AND THE SWIVEL UNION INVERTED CONE.

DIN swivel unions (Figure 16) have a 24° inverted cone and may be installed into DIN bite-ring compression fittings. To provide enhanced performance, an O-ring is sometimes included in the cone of some DIN swivel unions. (Figure 16 Detail A)

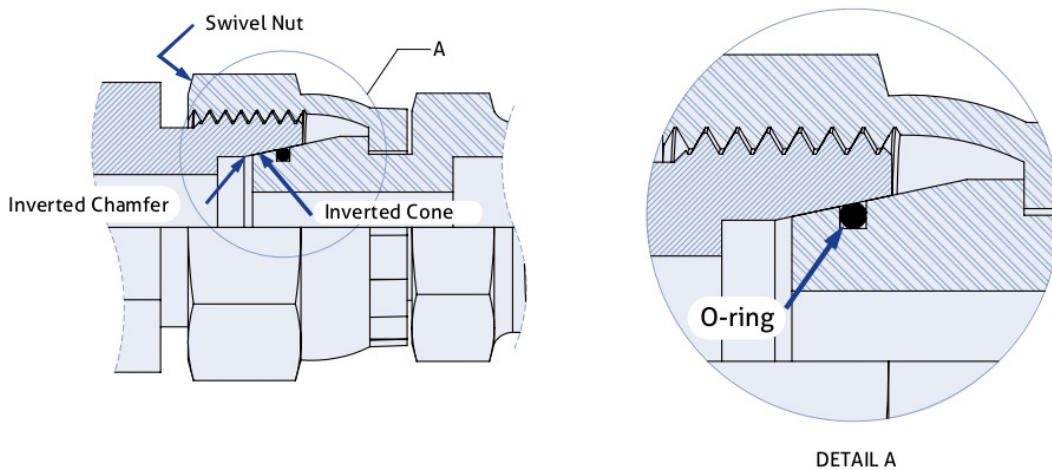

Figure 16: DIN Swivel Union

British Standard Pipe Parallel (BSPP, DIN 3852-2, ISO 1179-1) and Metric Parallel (DIN 3852-1, ISO 9974-1) threaded ports do not include a port cavity like the O-ring Boss or ISO 6149 port. Instead, an O-ring sits on top of the spot face or external surface and is surrounded by a metal retaining ring or other retaining component to trap the O-ring between the fitting hex, body, and spot face. (Figure 17)

Elbow and Tee fittings have a locknut, backup washer, O-ring and retaining washer to permit 360° orientation around the axis of the port. (Figure 18)

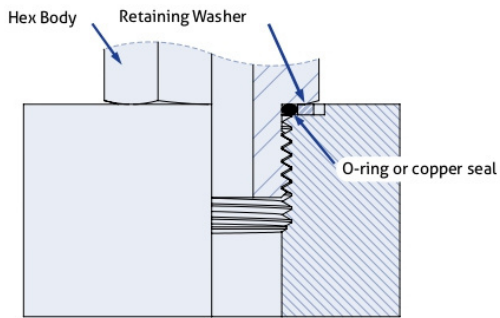

Figure 17: BSPP & Metric Straight (DIN 3852-1 & -2)

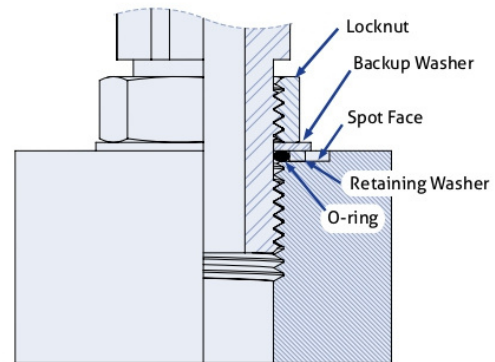
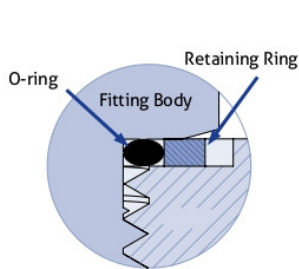

Figure 18: BSPP & Metric Adjustable (DIN 3852-1 & -2)

There are three sealing designs for either the BSPP or Metric parallel thread:

1. A retaining ring and O-ring. Some straight fittings may have a seal that is bonded in to the inside edge of a washer. This is known as a bonded seal or a Dowty seal (not shown). For extreme heat applications, straight fittings may include a copper washer for a seal. (Figure 19)
2. Cutting face metal seal between the fitting and the spot face. (Figure 20)
3. Elastomeric (ED) seal or P-Flex seal. A precision groove is machined on the bottom of the fittings hex with a seal installed in this groove. For the parallel fittings, the threads are for holding power or clamping force only and the seal occurs on the spot face. For tapered BSPT fittings the holding and sealing is done in the threads with the help of a pipe sealant such as PTFE tape or an anaerobic liquid. (Figure 21)



**Figure 19:
Retaining Ring with O-ring Seal**

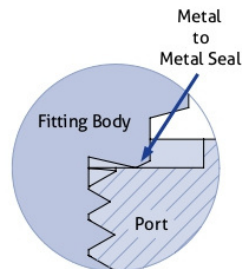

**Figure 20:
Cutting Face Seal**

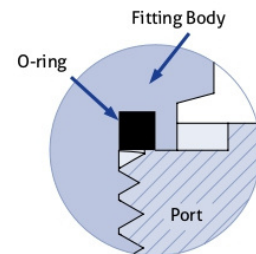

**Figure 21:
Elastomeric Seal**

The following table lists the specifications for BSPP & BSPT adapters.

BSPP & BSPT Specifications				
Dash Size	BSPT & BSPP		Torque	
	THREAD SIZE	MAJOR OD*	BSPP Swivel Union	BSPT
		(inch)	(FFWR)	(TFFT)
02	1/8-28	0.383	2	2-3
04	1/4-19	0.518	2	2-3
06	3/8-19	0.656	2	2-3
08	1/2-14	0.825	2	2-3
10	5/8-14	0.929	2	2-3
12	3/4-14	1.041	2	2-3
16	1-11	1.309	1 1/2	1 1/2 - 2 1/2
20	1 1/4-11	1.650	1 1/2	1 1/2 - 2 1/2
24	1 1/2-11	1.882	1 1/2	1 1/2 - 2 1/2
32	2-11	2.347	1 1/2	1 1/2 - 2 1/2

*Reference ISO-228-1, Table 1

Table 9: BSPP & BSPT Specifications

The following table lists the specifications for Metric adapters.

Metric DIN 3852-1 Threads	
Dash Size	THREAD SIZE
	(mm)
08	8 x 1.0
10	10 x 1.0
12	12 x 1.5
14	14 x 1.5
16	16 x 1.5
18	18 x 1.5
20	20 x 1.5
22	22 x 1.5
24	24 x 1.5
26	26 x 1.5
27	27 x 2.0
30	30 x 2.0
33	33 x 2.0
39	39 x 2.0
42	42 x 2.0
48	48 x 2.0
60	60 x 2.0

Values are from DIN 3852-1 & ISO 9974-1

Table 10: Metric DIN 3852-1 Threads

Metric Compression Tube (DIN LL, L, & S) Adapter Specifications

You can use a metric compression tube adapter with different types of fitting connections that use a metric tube size. The DIN figure to the right shows the cross sectional cut of a DIN connection. The Tube Pilot dimension is P. The thread size is the Thread O.D.

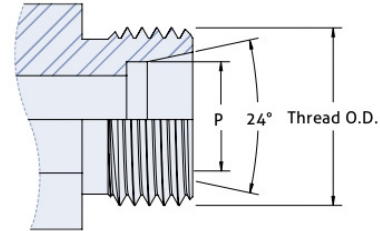

Figure 22: DIN Identification

The following table lists the specifications for DIN LL adapters.

DIN LL			
Metric Tube O.D. Size	Thread O.D.	Tube (P)ilot	Pressure
(mm)	(mm)	(mm)	(psi)
4	8 x 1.0	4	1500
6	10 x 1.0	6	1500
8	12 x 1.0	8	1500
10	14 x 1.0	10	1500
12	16 x 1.0	12	1500

*Meets standard ISO 8434-1

Table 11: DIN LL

The following table lists the specifications for DIN S adapters.

DIN L			
Metric Tube O.D. Size	Thread O.D.	Tube (P)ilot	Pressure
(mm)	(mm)	(mm)	(psi)
6	12 x 1.5	6	3600
8	14 x 1.5	8	3600
10	16 x 1.5	10	3600
12	18 x 1.5	12	3600
15	22 x 1.5	15	3600
18	26 x 1.5	18	2300
22	30 x 2.0	22	2300
28	36 x 2.0	28	1500
35	45 x 2.0	35	1500
42	52 x 2.0	42	1500

*Meets standard ISO 8434-1

Table 12: DIN L

The following table lists the specifications for DIN L adapters.

DIN S			
Metric Tube O.D. Size	Thread O.D.	Tube (P)ilot	Pressure
(mm)	(mm)	(mm)	(psi)
6	14 x 1.5	6	9000
8	16 x 1.5	8	9000
10	18 x 1.5	10	9000
12	20 x 1.5	12	9000
14	22 x 1.5	14	5800
16	24 x 1.5	16	5800
20	30 x 2.0	20	5800
25	36 x 2.0	25	5800
30	42 x 2.0	30	3600
38	52 x 2.0	38	3600

*Meets standard ISO 8434-1

Table 13: DIN S

Metric ISO 6149 Adapter Specifications

These types of fittings are similar in design to the SAE O-ring Boss fittings but with a metric thread.

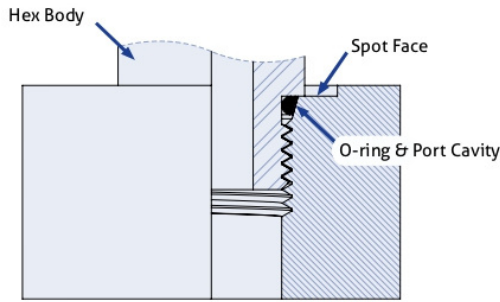

Figure 23: Straight ISO 6149

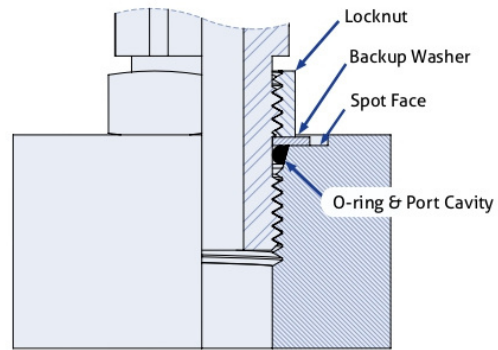

Figure 24: Adjustable ISO 6149

NOTE: THE RATINGS OF THE ISO 6149 FITTING ARE DIFFERENT THAN ITS COUNTERPART SAE O-RING BOSS.

The following table lists the specifications for Metric ISO 6149 adapters.

Metric ISO 6149 Specifications								
Dash Size	Tube Size	Thread	Light Duty			Heavy Duty		
			Adjustable & Non-Adjustable	Working Pressure		Adjustable & Non-Adjustable	Working Pressure	
				Adjustable	Non-Adjustable		Adjustable	Non-Adjustable
				(ft-lbs) +25% -0%	(psi)		(psi)	(ft-lbs) +25% -0%
08	4	8 x 1.0	6	4500	5800	7	-	-
10	5	10 x 1.0	11	4500	5800	15	5800	9100
12	6	12 x 1.5	18	4500	5800	26	5800	9100
14	8	14 x 1.5	26	4500	5800	33	5800	9100
16	10	16 x 1.5	30	3600	4500	40	5800	9100
18	12	18 x 1.5	33	3600	4500	52	5800	9100
22	16	22 x 1.5	44	3600	4500	74	5800	9100
27	20	27 x 2.0	75	2300	2900	125	5800	5800
30	22	30 x 2.0	95	2300	2900	158	5800	5800
33	25	33 x 2.0	120	2300	2900	228	5800	5800
42	30	42 x 2.0	155	2300	2900	243	4500	3600
48	38	48 x 2.0	190	2300	2900	310	2900	3600
60	50	60 x 2.0	230	1450	2300	369	2300	3600

* = Light Duty per SAE J2244/3
 ** = Heavy Duty per SAE J2244/2

Torque values are for wet torque only and are allowed up to 25% the listed value according to SAE J2593 recommendations. Reduce torque values for softer material components.

Table 14: Metric ISO 6149 Specifications

Compression & Flared Adapter Thread Sizes

The following table lists the compression and flared fitting thread sizes.

Compression & Flared Fitting Thread Sizes					
Dash Size	Tube Size	Steel Compression *	Brass SAE 45° Flare **	Brass Inverted Flare **	Brass SAE Compression **
02	1/8	5/16-24	5/16-24	5/16-28	5/16-24
03	3/16	3/8-24	3/8-24	3/8-24	3/8-24
04	1/4	7/16-20	7/16-20	7/16-24	7/16-24
05	5/16	1/2-20	1/2-20	1/2-20	1/2-24
06	3/8	9/16-18	5/8-18	5/8-18	9/16-24
08	1/2	3/4-16	3/4-16	3/4-18	11/16-20
10	5/8	7/8-14	7/8-14	7/8-18	13/16-18
12	3/4	1 1/16-12	1-1/16-14	1-1/16-16	1-18
14	7/8	1 3/16-12	1-1/4-12	-	-
16	1	1 5/16-12	1-3/8-12	-	-
20	1 1/4	1 5/8-12	-	-	-
24	1 1/2	1 7/8-12	-	-	-
32	2	2 1/2-12	-	-	-

* Values are per SAE J514 standard thread sizes.
 ** Values are per SAE J512 standard thread sizes

Table 15: Compression & Flared Fitting Thread Sizes

JIS & Komatsu® Adapter Thread Sizes

The following tables list the JIS and Komatsu® specifications.

JIS Specifications	
Dash Size	THREAD SIZE
02	1/8-28
04	1/4-19
06	3/8-19
08	1/2-14
10	5/8-14
12	3/4-14
16	1-11
20	1 1/4-11
24	1 1/2-11
32	2-11

Table 16: JIS Specifications

Komatsu®	
Dash Size	THREAD SIZE
14	14 x 1.5
18	18 x 1.5
22	22 x 1.5
24	24 x 1.5
30	30 x 1.5
33	33 x 1.5

Table 17: Komatsu®

Code 61 (Standard Pressure) Flanges

The following table lists the specifications for Code 61 flanges.

Flange Code 61 Specifications				
Dash Size	Tube Size	Working Pressure	Torque*	Torque**
		(psi)	+10% - 0% (ft-lbs)	+10% - 0% (ft-lbs)
08	1/2	5000	18	24
12	3/4	5000	32	44
16	1	5000	32	44
20	1 1/4	4000	52	68
24	1 1/2	3000	77	111
32	2	3000	77	111
40	2 1/2	2500	77	111
48	3	2000	155	217
56	3 1/2	500	155	217
64	4	500	155	217

Torque values are per SAE J2593 and for wet installation of steel components. Reduce torque values for softer material components.

* Torque for SAE Grade 5 Screws
** Torque for SAE Grade 8 Screws

Table 5: Flange Code 61 Specifications

The following table lists the dimensions for Code 61 flanges.

Flange Code 61 Dimensions								
Dash Size	Tube Size	C	E	Q	GG	A	Z INCH Threads	Z METRIC Threads
08	1/2	1.188	0.265	1.5	0.688	0.50	5/16-18	M8 x 1.25
12	3/4	1.500	0.265	1.875	0.875	0.75	3/8-16	M10 x 1.5
16	1	1.750	0.315	2.082	1.031	1.00	3/8-16	M10 x 1.5
20	1 1/4	2.000	0.315	2.312	1.188	1.25	7/16-14	M10 x 1.5
24	1 1/2	2.375	0.315	2.750	1.406	1.50	1/2-13	M12 x 1.75
32	2	2.812	0.375	3.062	1.688	2.00	1/2-13	M12 x 1.75
40	2 1/2	3.312	0.375	3.500	2.000	2.50	1/2-13	M12 x 1.75
48	3	4.000	0.375	4.188	2.438	3.00	5/8-11	M16 x 2
56	3 1/2	4.500	0.422	4.750	2.750	3.50	5/8-11	M16 x 2
64	4	5.000	0.442	5.125	3.062	4.00	5/8-11	M16 x 2

Hex head bolts are grade 5 and socket head cap bolts are grade 8.

Table 6: Flange Code 61 Dimensions

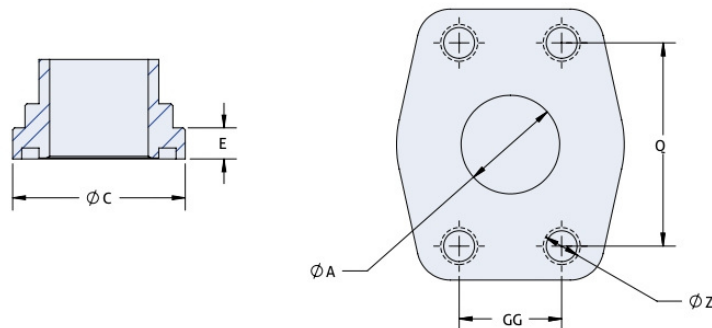

Figure 13 : Code 61 and 62 Figures of the flange (Left) and bolt pattern (Right)